

DECORQUIP

Classic Roman Blind Headrail

Warning - the operating instructions must be read before operating the blind.

Fitting Instructions

This procedure can be completed by non-professionals.

1. Position the brackets 100mm from each end of the track and then evenly space the other brackets across the headrail.
2. If necessary, make a pencil mark through the brackets and drill and plug pilot holes where you have marked.
3. Fix the brackets securely using suitable fixings and move the swivel lever to the right so that it is protruding at 90 degrees to the bracket.
4. With the headrail slightly tilted backwards, hook the front of the bracket into the front groove of the headrail, then raise the rear of the headrail so that it touches the bottom of the bracket.
5. Push the swivel lever from right to left until it is flush against the headrail. This secures the headrail.
6. For spring brackets, hook the headrail into the front of the bracket and push away from you until the bracket clips into place.
7. Fit the chain safety device (fixed tensioning device only).
8. If your headrail is fitted with a 401706 Breakaway Mechanism, the breakaway component can be secured by positioning it with the screw on the outer side (as illustrated) and firmly pushing up into the mechanism housing until it clicks securely into place.

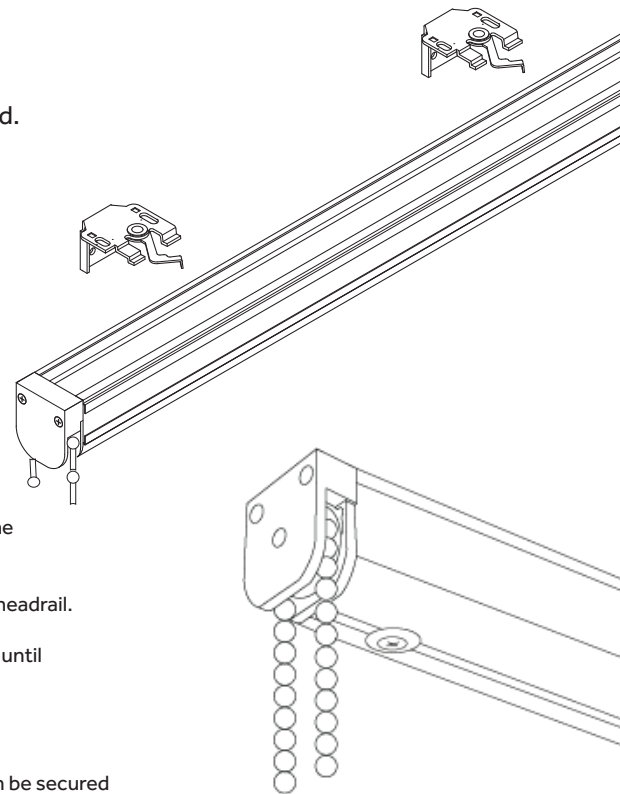

401628
Breakaway 1:4
Geared Mechanism

Operating Instructions

1. Pull the chain to open or shut the blind.
2. Do not lift the blind up further than necessary as pulling the blind up too far can damage the blind.
3. If the clear chain connector child safety devices separate, then clip the two parts of the safety device back together and operate the blind as normal.
4. If you have the 401706 Breakaway Mechanism 1:4 and it breaks away, refer to point 8 of the fitting instruction to fit back together.

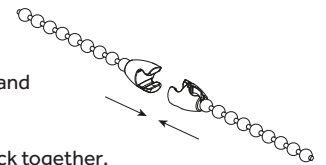

Care Instructions

1. Provided the Roman headrail has been installed correctly it will not require any maintenance.
2. An occasional wipe with a dry cloth will maintain it in good condition.
3. Ask your retailer for information on maintaining the fabric, lining and safety devices.
4. Do not make alterations to the blind, chain or safety device.

Fitting the Safety Device: 'P' Clip 400990

1. Once the headrail has been fitted, position the 'P' Clip at the maximum distance possible from the control mechanism to prevent the looped pull chain becoming slack.
2. Make a mark through the screw holes.
3. Move the device to one side and using the marks made in step 2, drill and plug the holes.
4. Fix into position so that the device is securely mounted.

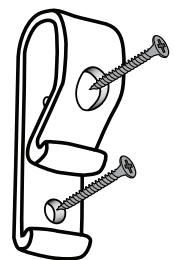

**Children can be strangled if a safety device is not installed.
Always use this device to keep cords or chains out of reach of children.**

DECORQUIP

Fitting Safety Clear Cord Adjuster 401657

1. Make your roman blind with normal rings or eyelets at each rod pocket.
2. Secure the safety devices securely to the bottom rod pocket through the handle so they cannot fall on to the floor. You can either sew the device on, or use a zip-tie or a strip of cloth sewn round the handle.
3. Squeeze the cord adjuster together and thread the cord through the hole in the centre of the device. Releasing the device will clamp the cord.
4. In the event of the cord pulling through the safety device and releasing, repeat step 2.



Please note that you must not burn or knot the cord below the safety device.

**Children can be strangled if this safety device is not installed.
Always use this device to keep cords or chains out of reach of children.**

If you have requested a different safety device, the instructions will be packed separately.



WARNING



Young children can be strangled by loops in pull cords, chains, tapes and inner cords that operate the product.

To avoid strangulation and entanglement, keep cords out of the reach of young children. Cords may become wrapped around a child's neck.

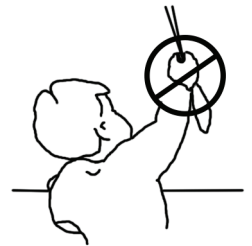

Move beds, cots and furniture away from window covering cords.

Do not tie cords together. Make sure cords do not twist and create a loop.

Always fit the chain and rear cord safety devices.